

Parameter	Specification
Size	φ52 mm (no rubber gasket), Height=21mm
Impedance	8Ω ± 15%
Input Power	1.0W/3.0W
Lowest Resonant Frequency, F ₀	145Hz ± 20%
SPL	80 ± 3 dB (1W/1m)
Effective Frequency Range	F ₀ to 15.0 kHz
V _{as}	0.22 L
Q _{ts}	1.39

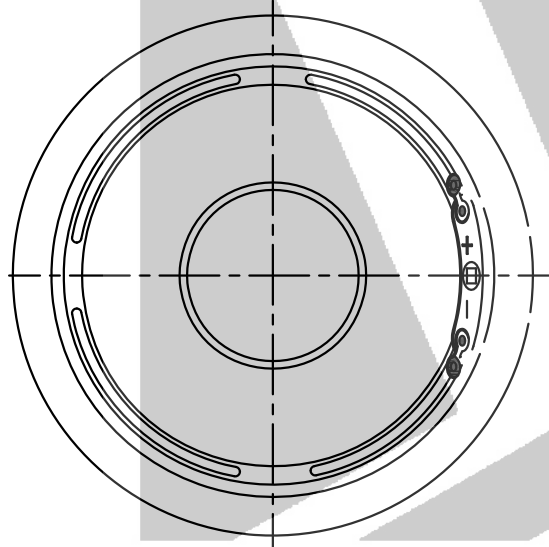

Typical Frequency Response

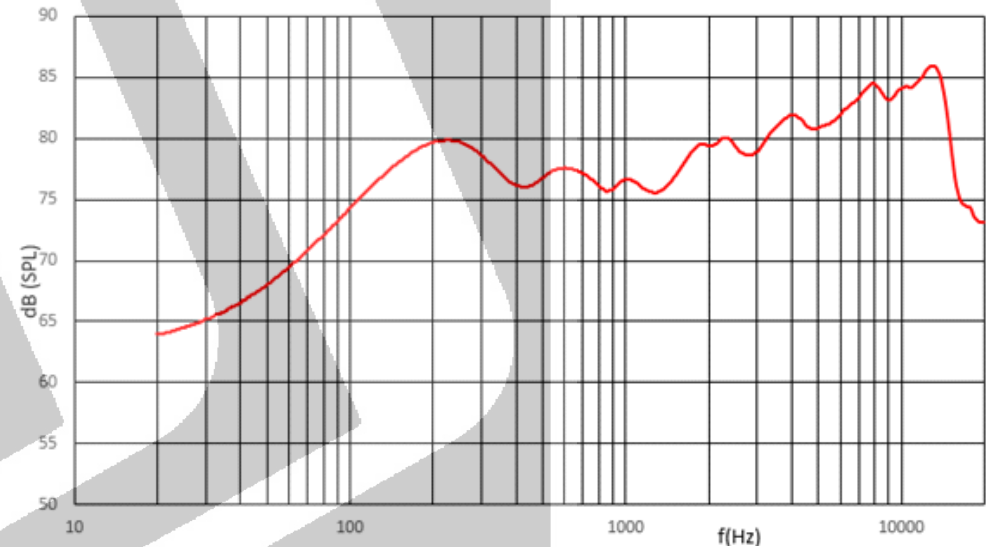

STETRON

*Specifications subject to change

Part No. D0052008NR003AR

Speaker size: Ø52mm x 21mm (H)

Web Site: www.stetron.com

